

apply this method in actual calculations of the band structure over most of the zone using only the second-order parameters. In fact, one would be able to obtain a complete picture of the whole spectrum by making use of the higher-order expansion parameters and, if needed, by calculating  $E(\vec{k})$  separately only at a few points and in those portions of the zone that might be inaccessible by the expansion parameters. Such expansions will give the band structure itself [rather than an interpolation Hamiltonian whose secular determinant still needs to be evaluated in order to get  $E(\vec{k})$ ] in terms of only a small number of parameters. This in turn will greatly simplify the calculation of such quantities as the density of states, etc. In addition, this procedure is well suited to accurately resolve the detailed band structure of "pockets" of states in those regions of the zone which are of particular physical importance. Here we note that expansions with the relativistic coefficients will accurately determine the small spin-orbit coupling parameters which are of critical importance in such contexts

as magnetic breakdown,  $g$  factors, etc. Also, with appropriate modifications for nonmuffin-tin potentials, it might not be too optimistic, perhaps, to extend even to semiconductors these selective studies of important regions of the zone.

What is more important, however, than the calculational merits of this expansion procedure is the fact that it can be used in semiempirical contexts as an interpolation scheme. Moreover, in contrast with other interpolation schemes where the adjustable parameters are of no direct physical significance, the fitting parameters of this scheme are the effective-mass parameters of this work which are expressed explicitly in terms of the phase shifts of the *real* (rather than pseudo) crystal potential. Therefore, blending these first-principles formulas with empirical information will put useful constraints on the phase shifts and thus, in turn, will provide specific information about the underlying crystal field.

Finally, we wish to thank Dr. F. S. Ham for providing the phase shifts for the alkali metals.

---

\*Research supported in part by the U.S. Atomic Energy Commission.

<sup>1</sup>C. Kittel, *Quantum Theory of Solids* (Wiley, New York, 1963).

<sup>2</sup>J. Bardeen, *J. Chem. Phys.* **6**, 367 (1938).

<sup>3</sup>M. H. Cohen and F. S. Ham, *J. Phys. Chem. Solids* **16**, 177 (1960).

<sup>4</sup>W. Kohn and N. Rostoker, *Phys. Rev.* **94**, 1111 (1954); J. Korringa, *Physica* **13**, 392 (1947); F. S. Ham and B. Segall, *Phys. Rev.* **124**, 1786 (1961).

<sup>5</sup>B. Segall and F. S. Ham, in *Energy Bands of Solids*,

Vol. 8 of *Methods in Computational Physics* (Academic, New York, 1968), p. 251.

<sup>6</sup>B. Segall and F. S. Ham, Document No. 7236 ADI Auxiliary Publications Project, Photoduplication Service, Library of Congress, Washington 25, D.C. (unpublished).

<sup>7</sup>G. Dressehaus, Ph.D. dissertation (University of California, 1955) (unpublished).

<sup>8</sup>Y. Onodera and M. Okazaki, *J. Phys. Soc. Japan* **21**, 1273 (1966); S. Takada, *Progr. Theoret. Phys. (Kyoto)* **36**, 224 (1966).

<sup>9</sup>F. S. Ham, *Phys. Rev.* **128**, 82 (1962).

## Cyclotron Resonance from a Fractional Orbit in Silver<sup>†</sup>

J. O. Henningsen\*

*Physics Department, University of Maryland,  
College Park, Maryland 20742*

(Received 6 July 1971)

Cyclotron resonance has been observed from a fraction of a dog's-bone orbit in silver under conditions where the carriers are effectively prevented from making more than two transits through the skin layer. In the high- $\omega_c\tau$  limit, the properties of such a resonance are shown to differ significantly from those of a conventional cyclotron-resonance spectrum. The requirements on the alignment of the sample surface relative to the crystal axis and on the flatness of the sample are very severe when the magnetic field points in a symmetry direction. These requirements are relaxed by an order of magnitude by a slight misorientation of the magnetic field.

A conventional Azbel'-Kaner<sup>1</sup> cyclotron-resonance experiment measures the cyclotron mass associated with a closed orbit in  $k$  space. A steady magnetic field is applied parallel to a flat metal surface, and

the resonance is caused by the multiple interaction between the electromagnetic field and electrons passing through the skin layer once per revolution. In the case of a concave orbit, a situation may arise

in which two or more points are located in the skin layer. This will give rise to separate resonance series which, in some respects, have properties differing from those of conventional cyclotron resonance. In the following, this effect will be treated for the specific case of the dog's-bone orbit in silver.

If the sample surface is a  $(\bar{1}10)$  plane and the magnetic field is along the  $[110]$  direction, the orbit is located with respect to the sample surface as shown in Fig. 1. During each cyclotron period the electron goes through the skin layer twice, at the points  $A$  and  $B$ . A resonance in the surface impedance may therefore be expected whenever  $t_{AB} = nT$  ( $n = 1, 2, 3, \dots$ ), where  $t_{AB}$  is the time it takes the electron to go from  $A$  to  $B$ , and  $T$  is the microwave period. By analogy with conventional cyclotron resonance we may define an equivalent mass for the fractional orbit as  $m_{eq} = eBt_{AB}/2\pi$  (in MKS units). We expect  $m_{eq}$  to be close to  $\frac{1}{4}$  of the dog's-bone mass  $m_c$  because the electrons traverse approximately  $\frac{1}{4}$  of the entire dog's-bone orbit.

Figure 2 shows a recording of the cyclotron-resonance spectrum at 44.8 GHz. The sample was a plane-parallel slab of thickness  $D = 0.235$  mm, and we used a standard reflection spectrometer with magnetic field modulation. The temperature was 4.2 K. The strong signal above  $B_1$  is due to the  $[110]$  noncentral belly electrons. Below  $B_1$  the orbit diameter of these electrons is larger than the slab thickness, and the resonance is cut off. In this range is seen a series of oscillations, periodic in  $B^{-1}$ , and corresponding to a mass of  $m_{eq}/m_0 = 0.270 \pm 0.005$ , where  $m_0$  is the free-electron mass. Above  $B_1$ , this series can be seen as a modulation of the belly spectrum. From Fermi-surface calculations, as well as from previous measurements,<sup>2,3</sup> it is apparent that for the given orientation of the magnetic field no closed orbit exists with a mass of this value. However,  $\frac{1}{4}$  of the dog's-bone mass ( $m_c/m_0 = 1.02 \pm 0.01$ ) is reasonably close to the measured  $m_{eq}/m_0$ . When the magnetic field is tilted out of the sample surface, the amplitude of the belly resonance decreases rapidly due to the large drift velocity of the noncentral electrons.

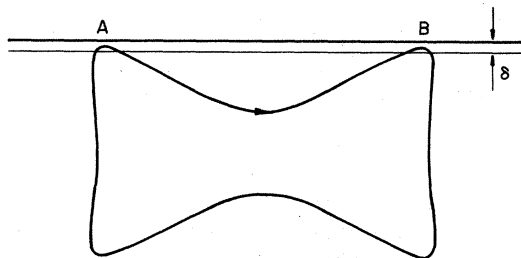

FIG. 1. Dog's-bone orbit with two effective points in the skin layer.

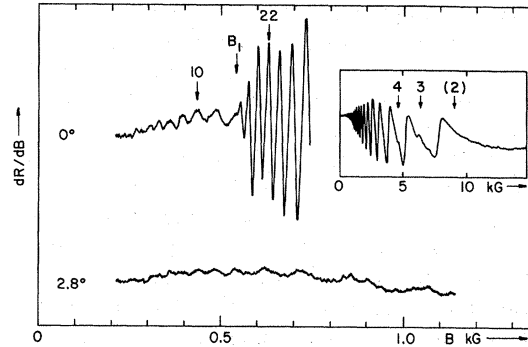

FIG. 2. Recording showing the fractional orbit resonance below belly electron cutoff. Insert shows harmonics Nos. 3 and 4 of the dog's-bone resonance, whereas No. 2 is missing.

At a tilt angle of  $2.8^\circ$  the belly resonance has disappeared, and the stationary fractional orbit resonance can be followed above the cutoff field  $B_1$ .

The existence along the orbit of two points of effective interaction with the microwave field can also be inferred from the behavior of the ordinary dog's-bone resonance. If the time  $t_{AB}$  equals an odd number of half-microwave periods, the net interaction will be zero. Since  $t_{AB} \approx \frac{1}{4} T_c$ , where  $T_c$  is the dog's-bone period, this can be expressed as  $\omega/\omega_c = 4p + 2$  ( $p = 0, 1, 2, \dots$ ). Thus the harmonics number 2, 6, ... should be missing from the dog's-bone spectrum, or at least appear with considerably reduced amplitude. This prediction is verified by the experimental recording inserted in Fig. 2, where the second harmonic is missing. Harmonics higher than the fourth are masked by the belly resonance. As a reasonable value of the mean free path for the dog's-bone electrons we may take 0.1 mm, corresponding to  $\omega\tau = 20$ . At the magnetic field  $B_1$ , this leads to  $\omega_c\tau = 0.7$ , so that the probability of completing one full dog's-bone orbit is down by a factor of  $10^{-3}$  as compared to the probability of completing the fractional orbit. The ordinary dog's-bone signal is therefore expected to be vanishingly small in the magnetic field range where we observe the fractional resonance.

It is of interest to compare the fractional resonance (subscript II) with a conventional cyclotron resonance<sup>4</sup> (subscript I). Assuming that only a small fraction  $\epsilon$  of the electrons, all of the same mass, contribute to the resonance, the conductivity for the conventional cyclotron resonance is

$$\sigma_I(q, B) = \sigma_0(q) \left( 1 - \epsilon + \frac{\epsilon}{1 - e^{-2\gamma\tau}} \right), \quad (1)$$

where  $\gamma = i\omega/\omega_c + 1/\omega_c\tau$  and  $\sigma_0(q)$  is essentially the conductivity associated with the nonresonant electrons. The resonance factor  $(1 - e^{-2\gamma\tau})^{-1}$  results from a summation of current contributions from

all previous traversals of the skin layer. For a fractional orbit, the number of traversals is restricted to two. The conductivity then is

$$\sigma_{II}(q, B) = \sigma_0(q) [1 - \epsilon + \epsilon (1 + e^{-2\pi\gamma})], \quad (2)$$

where  $1 + e^{-2\pi\gamma}$  are the two first terms in the sum leading to the resonance factor in (1). Strictly speaking, this result assumes that an electron is not allowed to complete an entire orbit. We can assure this for arbitrarily high  $\omega_c\tau$  values by choosing a sample so thin that the entire orbit is cut off. The surface impedance is proportional to  $\sigma^{-1/3}$ , and since  $\epsilon \ll 1$ , the expression for  $\sigma_{II}$  leads, for all  $\omega_c\tau$ , to

$$Z(B) = Z_0 + \Delta Z(B) \simeq Z_0 - \frac{1}{3}\epsilon |Z_0| e^{-2\pi\gamma + ix}, \quad (3)$$

where  $Z_0 = |Z_0| e^{ix}$  is the surface impedance associated with the majority of nonresonant electrons. For the fractional resonance we thus expect a purely sinusoidal modulation of the surface impedance. For the conventional resonance, if  $\omega_c\tau \ll 2\pi$ , we can expand the resonance factor and retain only the leading terms. In this limit  $\sigma_I$  is identical to  $\sigma_{II}$ , and the surface impedance is again given by (3). For high values of  $\omega_c\tau$ , however, the resonant term tends to peak strongly at the resonant fields where  $\omega = n\omega_c$ . If it remains small as compared with the nonresonant term, even at resonance, one then obtains the characteristic narrow, asymmetric Chambers line<sup>5</sup> whose relative width is of the order of  $1/\omega\tau$ .

In the general case, the cyclotron mass varies with  $k_B$  (the wave number component along  $\vec{B}$ ) and it is the integration over  $k_B$  that effectively reduces the number of electrons contributing to the resonance to a few, centered at the extremal value of  $m_c(k_B)$ . For the conventional resonance in the high- $\omega_c\tau$  limit this situation can be treated analytically by performing the  $k_B$  integration by the stationary phase method. This leads to Chambers lines which are qualitatively different for a mass maximum and a mass minimum, but with a relative width still of the order of  $1/\omega\tau$ . The validity of this approach requires a contributing range of  $k_B$  small enough so that we can use a parabolic expansion for  $m_c(k_B)$ . An electron whose mass deviates by  $\Delta m$  from the extremal value will, at the  $n$ th harmonic, see a change in the electromagnetic phase of  $2\pi n \Delta m/m$  per revolution. With an average of  $\omega_c\tau/2\pi$  revolutions in a lifetime, the accumulated phase change amounts to  $\omega\tau \Delta m/m$ , and only electrons satisfying  $\Delta m/m \lesssim 1/\omega\tau$  will then contribute. For sufficiently high  $\omega\tau$  this number will always be small enough to assure the validity of the parabolic expansion. For the fractional resonance there is no cumulative effect because the orbit is only traversed once. Thus, regardless the value of  $\omega\tau$ , all electrons with  $\Delta m/m$

$\lesssim 1/2\pi n$  will contribute to the  $n$ th harmonic. For low  $n$  this makes the use of stationary phase arguments questionable, and one may here anticipate substantial peak shifts due to the influence of electrons far from the mass extremum. In the present measurements we did not notice any peak shifts. This is to be expected, since with  $n=9$  the relative mass spread is less than the experimental uncertainty. The tilted field data cannot be used in this context since the drift velocity will here tend to reduce the contribution from the noncentral orbits.

It follows from the preceding discussion that the fractional orbit resonance will be a damped sinusoidal oscillation for all values of  $\omega_c\tau$ , in contrast to the conventional cyclotron resonance where narrow, asymmetric lines develop at high  $\omega_c\tau$ . The number of visible subharmonics in a fractional orbit spectrum will be identical to that of a conventional spectrum with the same mass and relaxation time, since in the low-field limit the two expressions for the surface impedance become identical. In view of this, it is not surprising that fractional orbit resonance can be observed experimentally. On the other hand, a serious difficulty with the observation of a fractional resonance would appear to be the necessary degree of alignment of the sample surface relative to the crystal axis. If the sample is flat and the alignment is not perfect, the two effective points on an orbit will be at different distances from the surface. The resonance will then be attenuated, and at the same time it will be shifted because the difference in the electromagnetic phase at points  $A$  and  $B$  will have an additional contribution due to the spatial variation of the field. Since the distance between the effective points in the present case is typically 0.3 mm and the skin depth is of the order of 0.1  $\mu$ , a misalignment of as little as  $1'$  would then be sufficient for destroying the resonance. When orienting our samples we used standard x-ray equipment allowing for an accuracy of, at most,  $\pm 0.5^\circ$ , and the probability for accidentally achieving alignment to better than  $1'$  can be considered negligible. The weak rounding of the chemically polished sample combined with the residual lemon-peel surface irregularities could compensate for a misalignment of up to  $10'$ , but even then only a small fraction of the sample area would be perfectly aligned, and we would expect the resonance to be extremely weak.

That a resonance can be observed in spite of such seemingly prohibitive conditions can be understood if we consider orbits with  $k_B \neq 0$ . Let us assume that the sample surface deviates by a small angle  $\alpha$  from the  $(1\bar{1}0)$  symmetry plane (Fig. 3). When  $\vec{B}$  points exactly along the  $[110]$  direction, the line adjoining the effective points  $A$  and  $B$  will, for all values of  $k_B$ , be inclined by an angle  $\alpha$  relative to the surface. If  $\vec{B}$  is slightly misaligned, as in the

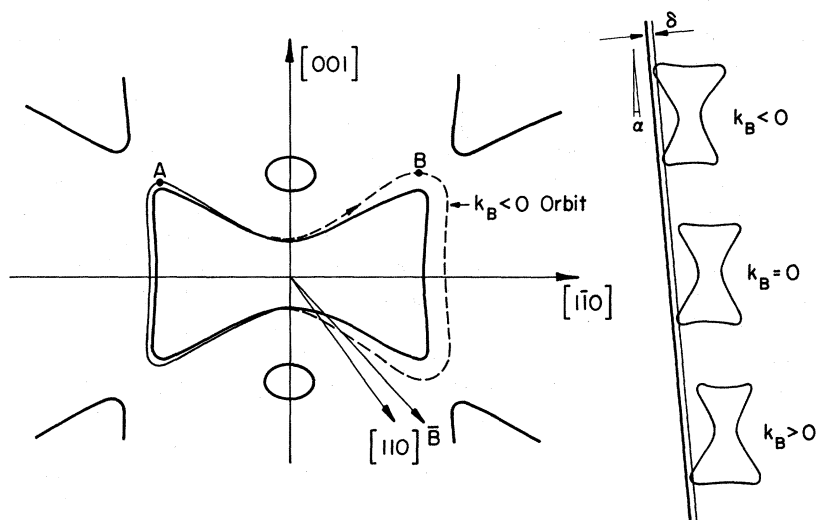

FIG. 3. Dog's-bone orbits for various  $k_B$ , with  $B$  tilted slightly away from the  $[110]$  symmetry direction.

figure, the orbits for  $k_B \neq 0$  will become asymmetric, so that for  $k_B < 0$  point  $A$  will move away from the surface and point  $B$  towards the surface, whereas for  $k_B > 0$  the motion will be in opposite directions. Thus, if  $\alpha$  is not too large, we can always find a value of  $k_B$  for which  $A$  and  $B$  will be at the same distance from the surface. In view of the fact that we observe 14 harmonics, the contributing electrons may have a mass spread of a few percent, and from the calculated  $m_c(k_B)^2$  we can then determine the allowed range of  $k_B$ . It turns out that if  $\vec{B}$  is oriented  $2^\circ$  away from  $[110]$ , one can compensate for an  $\alpha$  of  $\pm 0.4^\circ$ . All parts of the sample that are aligned to within  $0.4^\circ$  will then contribute to the resonance, and the requirements on the alignment and the flatness of the surface will have been relaxed by an order of magnitude.

We conclude that cyclotron resonance from fractional orbits can be observed without taking special precautions other than using a thin sample in order to eliminate interfering signals. By measuring the equivalent mass for such a resonance, one obtains information about the Fermi surface, adding to that obtained from conventional cyclotron resonance, and it is likely that this method can be extended to also cover open orbits. The problems concerning the alignment of the orbits relative to the sample surface are much smaller than immediately expected since, unless the magnetic field is pointing exactly along a symmetry direction, the Fermi surface has built-in features that, to some extent, compensate for small misalignments.<sup>6</sup>

I wish to thank Professor J. F. Koch for constructive criticism during many helpful discussions.

<sup>†</sup>Part of this work was performed while the author was at Physics Laboratory I, Technical University of Denmark, 2800 Lyngby, Denmark.

\*On leave from Physics Laboratory I, H. C. Ørsted Institute, Universitetsparken 5, Copenhagen, Denmark.

<sup>1</sup>M. Ya. Azbel' and E. A. Kaner, Zh. Eksperim. i Teor. Fiz. **30**, 811 (1956) [Sov. Phys. JETP **5**, 730 (1956)].

<sup>2</sup>N. E. Christensen, thesis (Technical University of Denmark, 1969) (unpublished).

<sup>3</sup>D. G. Howard, Phys. Rev. **140**, 1705 (1965).

<sup>4</sup>R. G. Chambers, in *The Physics of Metals*, edited by J. M. Ziman (Cambridge U. P., Cambridge, England, 1969), Chap. 4, Secs. 6 and 7.

<sup>5</sup>R. G. Chambers, Proc. Phys. Soc. (London) **86**, 305 (1965).

<sup>6</sup>A similar observation was made by W. M. Walsh [Phys. Rev. Letters **12**, 161 (1964)] in connection with normal-field cyclotron resonance from nonflat orbits in  $W$ .